

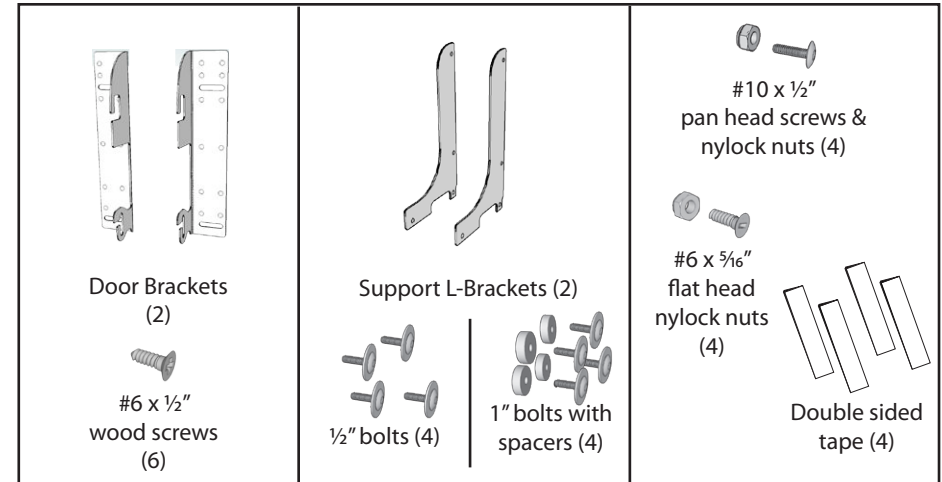

# Installation Instructions for the RV Door Mounting Kit

## Parts included



**Step 1:** Before beginning, ensure the waste container is installed per the installation instructions that were included and your cabinet door has been removed.

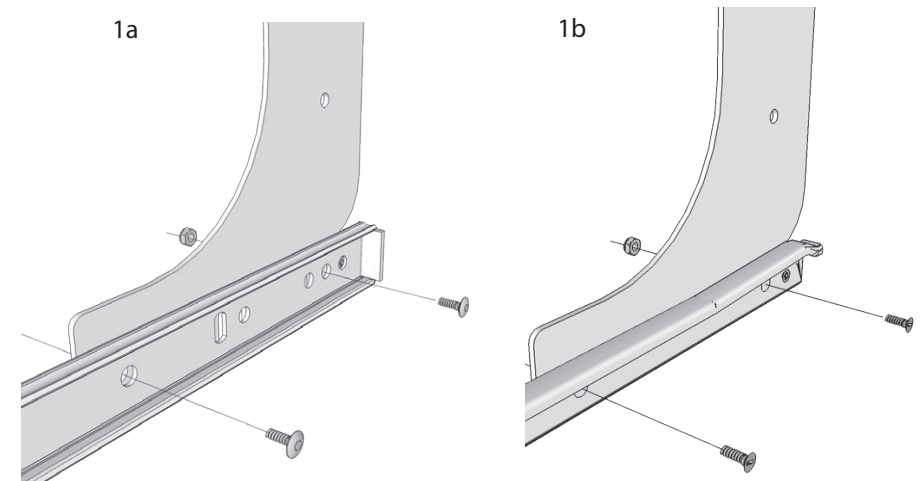

**Step 2a:** Ball Bearing Slides: Begin by mounting support L-brackets to slides by using the 4 - #10 x 1/2" pan head screws and nylock nuts provided. (see diagram 1a)

**Step 2b:** Euro Slides: Begin by mounting support L-brackets to slides by using the 4 - #6 x 5/16" flat head screws and nylock nuts provided. (see diagram 1b)



2409 Plantside Drive  
Jeffersontown, KY 40299  
1800-626-1126  
www.rev-a-shelf.com

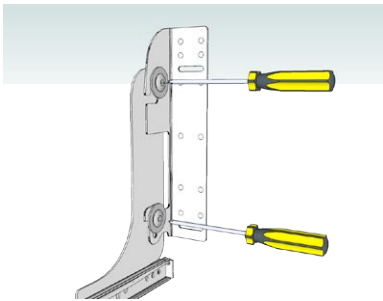

**Step 3:** Attach door brackets to the support L-brackets loosely with the ½" bolts as shown.



The door brackets should line up with the thick portion of the cabinet door.

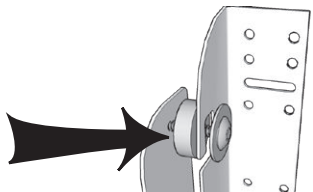

**NOTE:** If they do not line up with the thick portion of the door, use the provided spacers and longer 1" bolts to ensure mounting in the thick portion of the door.

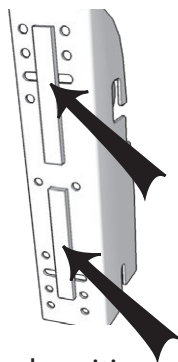

**Step 4:** With frame in closed position, apply double sided tape to brackets.

**Step 5:** Carefully line-up your desired door position by eyesight using the drawer above and any cabinets to the left or right as a gauge for correct alignment. (You will be able to adjust fully when door is attached to unit.)

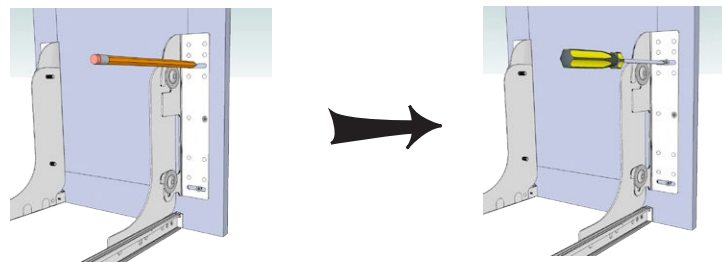

**Paso 7:** Marque la ubicación de los orificios en la parte gruesa de la puerta y instale los soportes en la puerta gabinete con los tornillos de madera num. 6 suministrados.

**Étape 7:** Marquer les positions de trous trouent dans la partie épaisse de la porte et monter les supports sur la porte de l'armoire avec les vis a bois no 6 fournies.

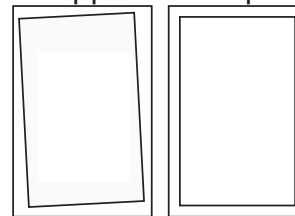

**Paso 8:** Para ajustar la puerta del armario si no está derecha (pareja a todo su alrededor), debe aflojar los tornillos en uno de los lados, alinear bien la puerta y volver a apretar los tornillos. **NOTA:** Si la puerta está paralela pero ligeramente descentrada, afloje los tornillos que sujetan las patas de las deslizaderas al piso del armario, mueva el ensamblaje lateralmente según sea necesario y vuelva a apretar los tornillos.

**Étape 8:** Si la porte de l'armoire est de travers, l'ajuster en desserrant les vis d'un côté ; puis corriger l'alignement de la porte et resserrer les vis.

**NOTE:** Si la porte est parallèle mais légèrement décentrée, desserrer les vis fixant les pattes de l'ensemble de glissières au fond de l'armoire. Glisser l'ensemble vers le côté jusqu'à ce que la position soit correcte et resserrer les vis.

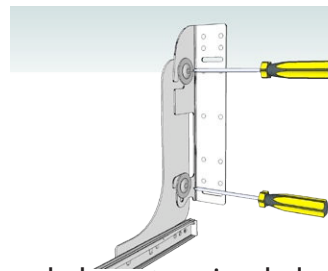

**Paso 9:** Cuando haya terminado los ajustes, apriete los pernos en los miembros del producto y los soportes de puerta.

**Étape 9 :** Après l'ajustement, serrer les boulons des équerres de renfort et des supports de porte.

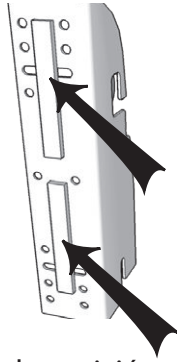

**Paso 4:** Ponga el bastidor en la posición cerrada y coloque cinta adhesiva de doble cara en los soportes.

**Étape 4 :** Avec le cadre en position fermée, appliquer du ruban adhésif à double face aux supports.

**Paso 5:** Alinee visualmente la puerta con cuidado, utilizando la gaveta de arriba y cualquier otro armario situado a la izquierda o derecha como referencia para hacerlo correctamente. (Podrá realizar un ajuste final una vez que haya instalado la puerta en la unidad.)

**Étape 5 :** Aligner ensuite soigneusement la porte en utilisant le tiroir d'au-dessus et les armoires sur les côtés, le cas échéant, comme jauge d'alignement correct. (L'ajustement final peut être fait après avoir attaché la porte au meuble.)

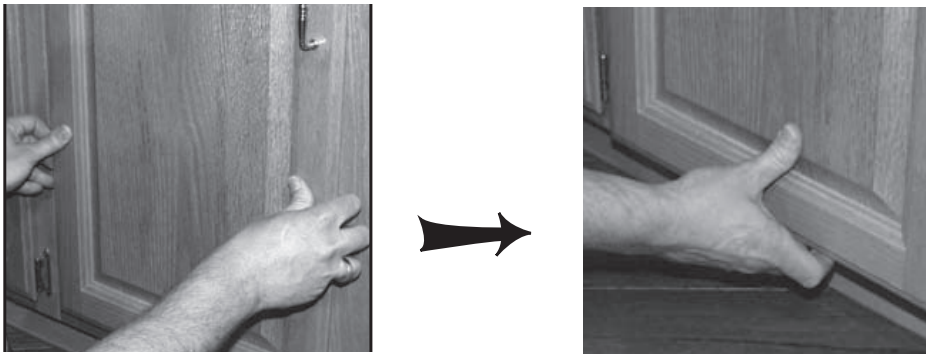

**Paso 6:** Presione la puerta para adherirla a los soportes y abra con cuidado la puerta con el cesto tirando de la parte inferior.

**Étape 6 :** Appuyer fermement sur la porte pour qu'elle adhère aux supports et ouvrir la poubelle en la tirant doucement par le bas.

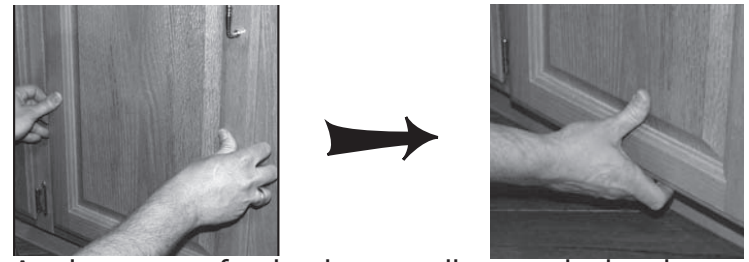

**Step 6:** Apply pressure for the door to adhere to the brackets and by pulling from the bottom, carefully pull open waste container.

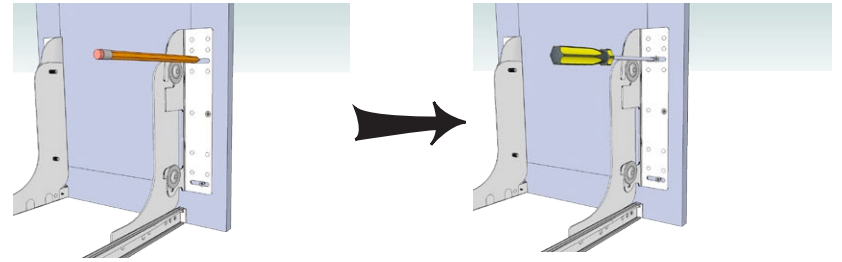

**Step 7:** Mark desired hole locations that are in the thick portions of the door and install the brackets to the cabinet door by using the provided #6 x 1/2" wood screws.

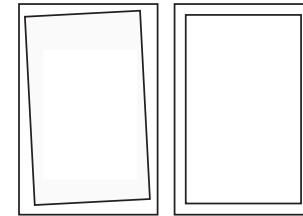

**Step 8:** If your cabinet door is not straight (even all around) you can adjust it by loosening the screws on one of the sides, properly align the cabinet door and re-tighten the screws. **NOTE:** If your door is parallel, but slightly off center, loosen screws that attach the slide mounting straps to the cabinet floor. Slide assembly sideways as needed and re-tighten screws.

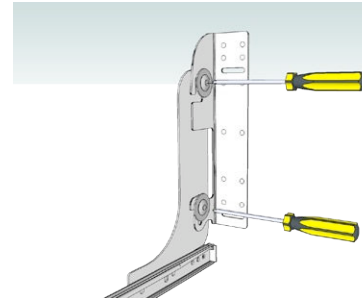

**Step 9:** Once adjusted, tighten bolts on the support L-brackets.

